

RoHS COMPLIANT

REVISIONS				
REV	ECN NO.	DESCRIPTION	APPROVED BY	DATE
A		⚠	KING CHIU	2006-06-03

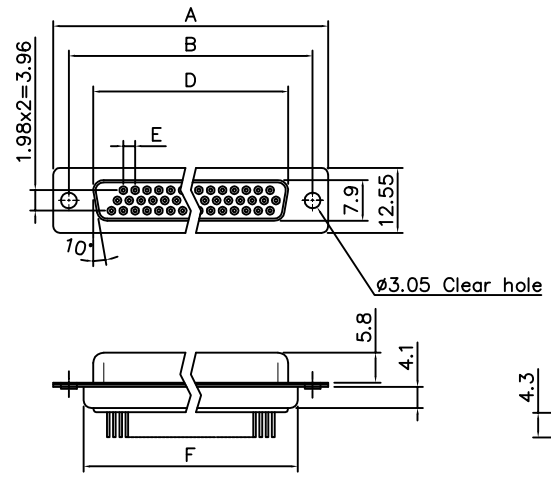

Product Specification

Material

Insulator : Glass-filled thermoplastic PBT, UL94V-0, TSU

Contact : Copper alloy 1x8^uya/vb/sW

Shell : Steel, 100u" Tin Over 50u" min Copper

Electrical

Contact Resistance : 20 milliohms

Insulation Resistance : 1000 magohms at 500 VDC

Dielectric Withstanding Voltage : 500 VAC/rms 60Hz for 1 minute

Current Rating : 3 AMP

Volatge Rating : 250 VAC/rms 60Hz

Dimensions

Positions	A	B	D	E	F
15	30.81	24.99	16.33	2.29	19.20
26	39.20	33.30	24.70	2.29	27.70
44	53.05	47.04	38.40	2.29	41.10
62	69.40	63.50	54.80	2.41	57.30

P.C.B LAYOUT PATTERN

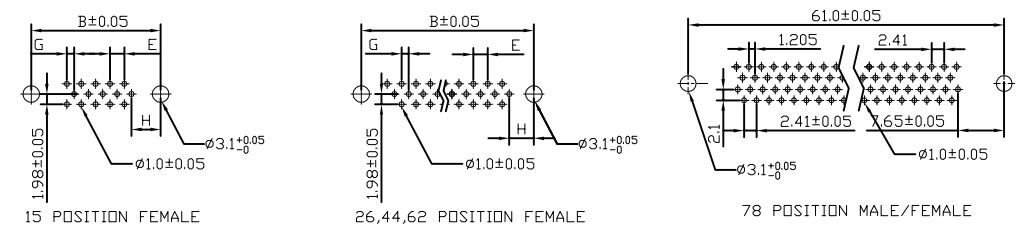

Positions	G
15M/F	1.145
26M/F	1.145
44M/F	1.145
62M/F	1.205

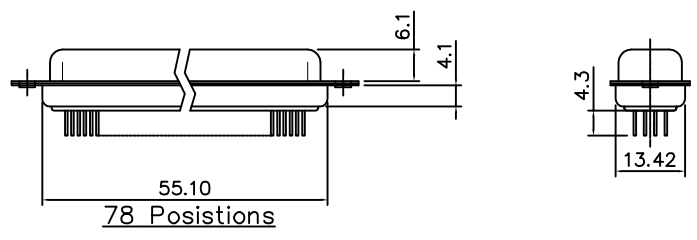
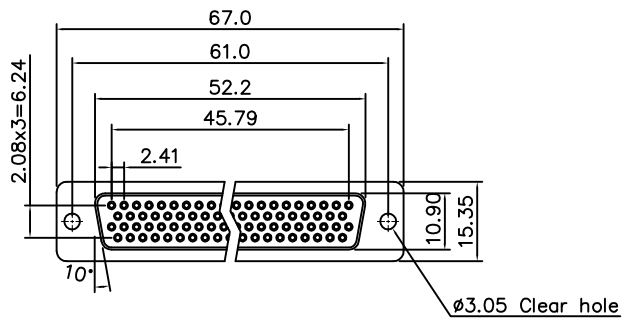

DO NOT SCALE DRAWING

<p>DIMENSIONS:</p> <p><input type="checkbox"/> mm [INCH] <input type="checkbox"/> INCH [mm] <input checked="" type="checkbox"/> mm ONLY</p> <p>UNLESS OTHERWISE SPECIFIED, GENERAL TOLERANCE:</p> <table style="font-size: small;"> <tr> <td>DECIMALS</td> <td>ANGLES</td> </tr> <tr> <td>.X ±0.38 [0.015]</td> <td>X° ±3°</td> </tr> <tr> <td>.X ±0.25 [0.010]</td> <td>.X° ±1.0°</td> </tr> <tr> <td>.XX ±0.13 [0.005]</td> <td></td> </tr> </table> <p>MATERIAL</p> <p>FINISH</p>	DECIMALS	ANGLES	.X ±0.38 [0.015]	X° ±3°	.X ±0.25 [0.010]	.X° ±1.0°	.XX ±0.13 [0.005]		<p>CAD GENERATED DRAWING, DO NOT MANUALLY UPDATE</p> <p>DRAWN BY AND DATE JUSTIN XING 05-18-02</p> <p>CHECKED BY AND DATE JUSTIN XING 06-03-02</p> <p>APPROVED BY AND DATE KING CHIU 06-03-02</p> <p>THIRD ANGLE PROJECTION</p> <p>SCALE: 1 : 1 SIZE: A3</p>	<p>gk GTK UK Ltd</p> <p>TITLE</p> <p>HIGH DENSITY VERTICAL D-SUB RECEPTACLE, Ø3.05 MOUNTING HOLES</p> <table style="width: 100%; font-size: small;"> <tr> <td style="width: 80%;">DRAWING NO. HDDxxSTK2NS-R</td> <td style="width: 20%;">REV A</td> </tr> <tr> <td>FILE NO.:</td> <td>SHEET 1 OF 1</td> </tr> </table>	DRAWING NO. HDDxxSTK2NS-R	REV A	FILE NO.:	SHEET 1 OF 1
DECIMALS	ANGLES													
.X ±0.38 [0.015]	X° ±3°													
.X ±0.25 [0.010]	.X° ±1.0°													
.XX ±0.13 [0.005]														
DRAWING NO. HDDxxSTK2NS-R	REV A													
FILE NO.:	SHEET 1 OF 1													